

TRAFFIC FORECAST REPORT
Lewis & Rowan Counties
KY 59 / KY 344 / KY 377
Item No. 9-231.00

Prepared for:



Prepared by:



TABLE OF CONTENTS

	Page
<u>1.0</u> <u>FIGURE 1 VICINITY MAP</u>	3
<u>2.0</u> <u>EXECUTIVE SUMMARY</u>	4
<u>3.0</u> <u>POPULATION SUMMARY</u>	6
<u>4.0</u> <u>EXISTING TRAFFIC</u>	8
<u>5.0</u> <u>BUILD / NO BUILD TRAFFIC</u>	13

Commonly Used Abbreviations and their Descriptions

ADT	K-30 th Hour Factor
DHV	Directional Factor
ESAL	Mile Point
%T	Automatic Traffic Recorder
FC	Kentucky Statewide Model
GR	
PHF	
K-Factor	Without any adjustment
D-Factor	30 th highest hour of a year
MP	A measure of traffic's impact on roadway
ATR	
KYSTM	The percentage of trucks to total volume
	Refers to a road's importance
Average Daily Traffic	A value normally compounded annually
Design Hour Volume	Considers a 15 minute spike in hourly count
Equivalent Single Axle Load	DHV divided by ADT
Truck Percentage	Percentage of dominant flow to total
Functional Class	Miles increase easterly and notherly
Growth Rate	A permanent & continuous recording station
Peak Hour Factor	A computerized representation of KY roads

Vicinity Map

Magoffin and Floyd Counties

Mountain Parkway Forecast

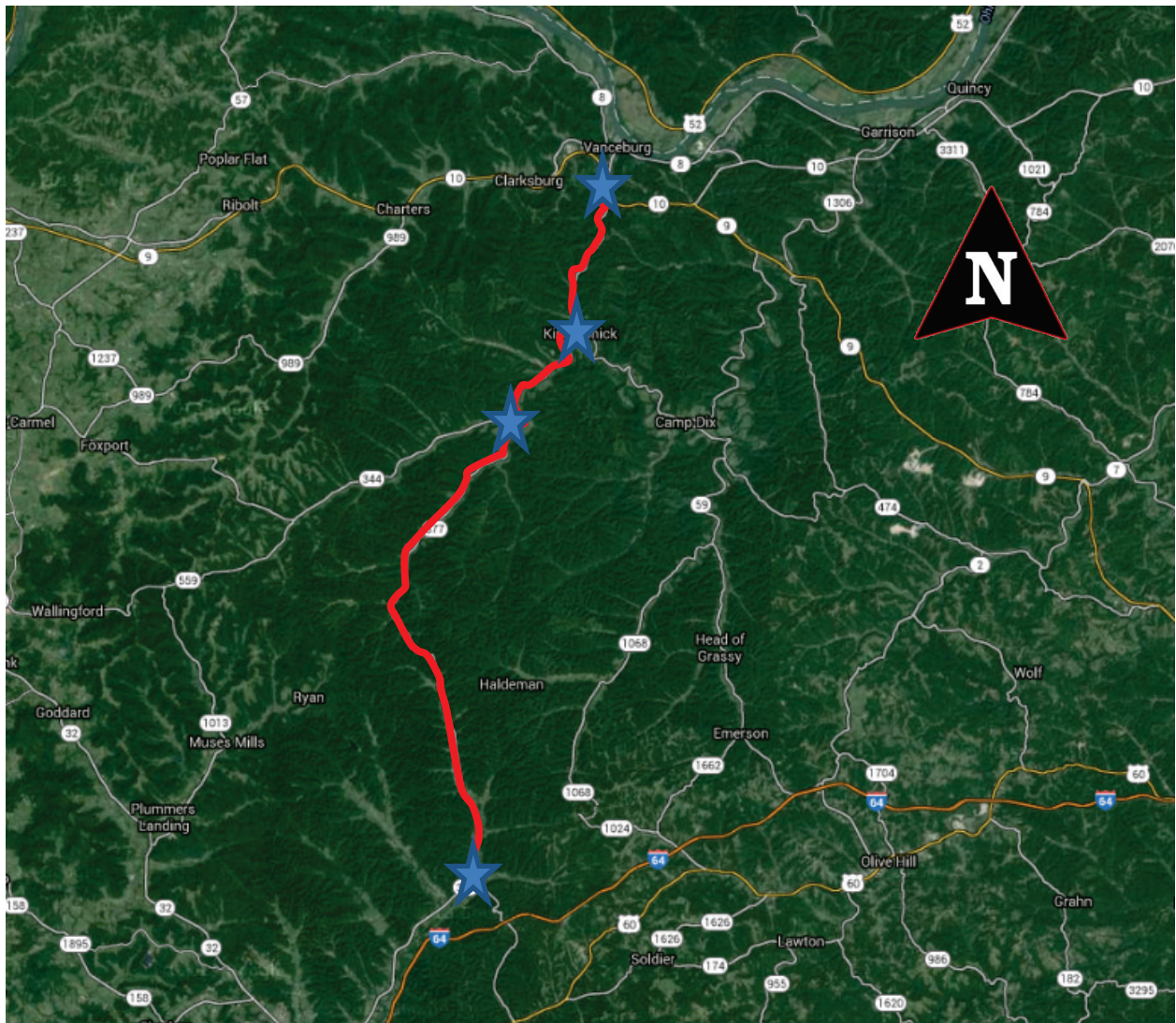

Traffic Forecast Executive Summary

Magoffin and Floyd Counties

Mountain Parkway Forecast

Forecast Summary

The project calls for the improvement of KY 59, KY 344 & KY 377 starting at KY 9 (AA Highway) in Vanceburg, MP 23.190 on KY 59, to KY 799 in Triplett, MP 8.049 on KY 377. The entire length of the studied corridor is 25.615 miles. The purpose of this report is to analyze current and future year traffic utilizing this facility. The forecast will be used for the design phase of this project to help determine future alignment, turn lane configuration, and number of lanes.

Forecast Type

The following types of forecasts were developed:

- 2015 & 2040 Truck Percentage Forecasts
- 2015 & 2040 DHV Values
- 2015 & 2040 Daily and Design Hour Turn Movements for No Build and Build Scenarios

Current Year Volumes

The 2015 ADT volumes were based on historical counts at traffic stations A44, A46, 799, 800, & 504 in Lewis County as well as stations 025 and 001 in Rowan County.

Design Year & Growth Factors

Lewis County has a 2010 population of 13,870 and an estimated 2040 population of 13,087. Rowan County has a 2010 population of 23,333 and an estimated 2040 population of 26,775. Both counties show little projected growth compared to Kentucky as a whole. Kentucky has a 2010 population of 4,339,367 and an estimated 2040 population of 5,162,292.

An analysis of historic traffic counts using the CTS spreadsheet resulted in the following:

<u>Route</u>	<u>County</u>	<u>Begin Milepoint</u>	<u>End Milepoint</u>	<u>Linear Growth Rate</u>	<u>Exponential Growth Rate</u>
KY 59	Lewis	18.093	21.389	0.00%	0.00%
KY 59	Lewis	21.389	22.647	0.00%	-0.19%
KY 344	Lewis	13.843	18.516	-0.66%	-1.34%
KY 377	Lewis	0	8.555	0.73%	0.73%
KY 377	Rowan	9.522	16.339	1.40%	2.81%
KY 377	Rowan	8.049	9.522	0.57%	0.57%

This analysis shows that these roadways have grown very little throughout the years, with several sections showing negative growth. Generally, the roadway sections with the lower ADT's had the higher growth rates.

Speed data was collected for all roadways in the study area using a data logger. This information was compared to speeds in the KY Statewide Travel Demand Model (statewide model) to see if increasing speeds in the model would result in increased assignment to study area roadways. However, the speeds in the statewide model (48mph – 55mph) were already higher than what was observed in the field.

A growth rate of 1% was used for all future forecasting and analysis purposes.

Truck Percentage

Truck percentages varied from 8.2% to 12.1% on the various roadway segments for this forecast. Zero percent growth rate was used for future year build / no build analysis.

Turn Movements

The turning movements at four intersections were collected and analyzed for this project. They occur at the following locations:

T1 – KY 59 & KY 9

T2 – KY 59 & KY 344

T3 – KY 344 & KY 377

T4 – KY 377 & KY 799

HISTORICAL POPULATION SUMMARY

	1960	1970	1980	1990	2000	2010	2014	60 - 70	70 - 80	80 - 90	90 - 00	00 - 10
Population	3,038,156	3,220,711	3,660,334	3,686,892	4,041,769	4,339,367	4,509,429	Change	Change	Change	Change	Change
Lewis Co	-	12,355	14,545	13,029	14,092	13,870	13,904	Pct	Pct	Pct	Pct	Pct
								6.0%	17.7%	-10.4%	8.2%	-1.6%

Sources: US Bureau of the Census; Kentucky State Data Center

FUTURE POPULATION PROJECTIONS SUMMARY

	2010	2015	2020	2025	2030	2035	2040	10 - 15	15 - 20	20 - 25	25 - 30	30 - 35
Population	4,339,367	4,509,429	4,672,754	4,820,390	4,951,178	5,083,331	5,162,292	Change	Change	Change	Change	Change
Lewis Co	13,870	13,904	13,899	13,818	13,637	13,385	13,097	Pct	Pct	Pct	Pct	Pct
								0.2%	0.0%	-0.6%	-1.3%	-1.8%

Sources: US Bureau of the Census; Kentucky State Data Center

ANNUAL POPULATION GROWTH RATES FROM HISTORICAL DATA AND PROJECTIONS

	60 - 70	70 - 80	80 - 90	90 - 00	05 - 10	10 - 15	15 - 20	20 - 25	25 - 30	10 - 30	15 - 40
GR	0.59%	1.28%	0.07%	0.92%	0.77%	0.71%	0.62%	0.54%	0.45%	0.53%	0.52%
Lewis Co	-	1.65%	-1.09%	0.79%	0.05%	-0.01%	-0.12%	-0.26%	-0.37%	-0.02%	-0.23%

HISTORICAL POPULATION SUMMARY

	1960	1970	1980	1990	2000	2010	2014	60 - 70	70 - 80	80 - 90	90 - 00	00 - 10
Population	3,038,156	3,220,711	3,660,334	3,686,892	4,041,769	4,339,367	4,509,429	Change	Change	Change	Change	Change
Rowan Co	-	17,010	19,049	20,353	22,094	23,333	24,067	Pct	Pct	Pct	Pct	Pct
								6.0%	12.0%	6.8%	8.6%	5.6%

Sources: US Bureau of the Census; Kentucky State Data Center

FUTURE POPULATION PROJECTIONS SUMMARY

	2010	2015	2020	2025	2030	2035	2040	10 - 15	15 - 20	20 - 25	25 - 30	30 - 35
Population	4,339,367	4,509,429	4,672,754	4,820,390	4,951,178	5,083,331	5,162,292	Change	Change	Change	Change	Change
Rowan Co	23,333	24,067	24,708	25,269	25,862	26,342	26,775	Pct	Pct	Pct	Pct	Pct
								3.1%	2.7%	2.3%	2.3%	1.9%

Sources: US Bureau of the Census; Kentucky State Data Center

ANNUAL POPULATION GROWTH RATES FROM HISTORICAL DATA AND PROJECTIONS

	60 - 70	70 - 80	80 - 90	90 - 00	05 - 10	10 - 15	15 - 20	20 - 25	25 - 30	10 - 30	15 - 40
GR	0.59%	1.29%	0.07%	0.92%	0.77%	0.71%	0.62%	0.54%	0.45%	0.53%	0.52%
Rowan Co	-	1.14%	0.66%	0.82%	0.62%	0.45%	0.47%	0.37%	0.40%	0.40%	0.41%

Existing / No Build / Build on Existing Alignment Traffic Volumes

Lewis & Rowan Counties

KY 59 / KY 344 / KY 377 Forecast

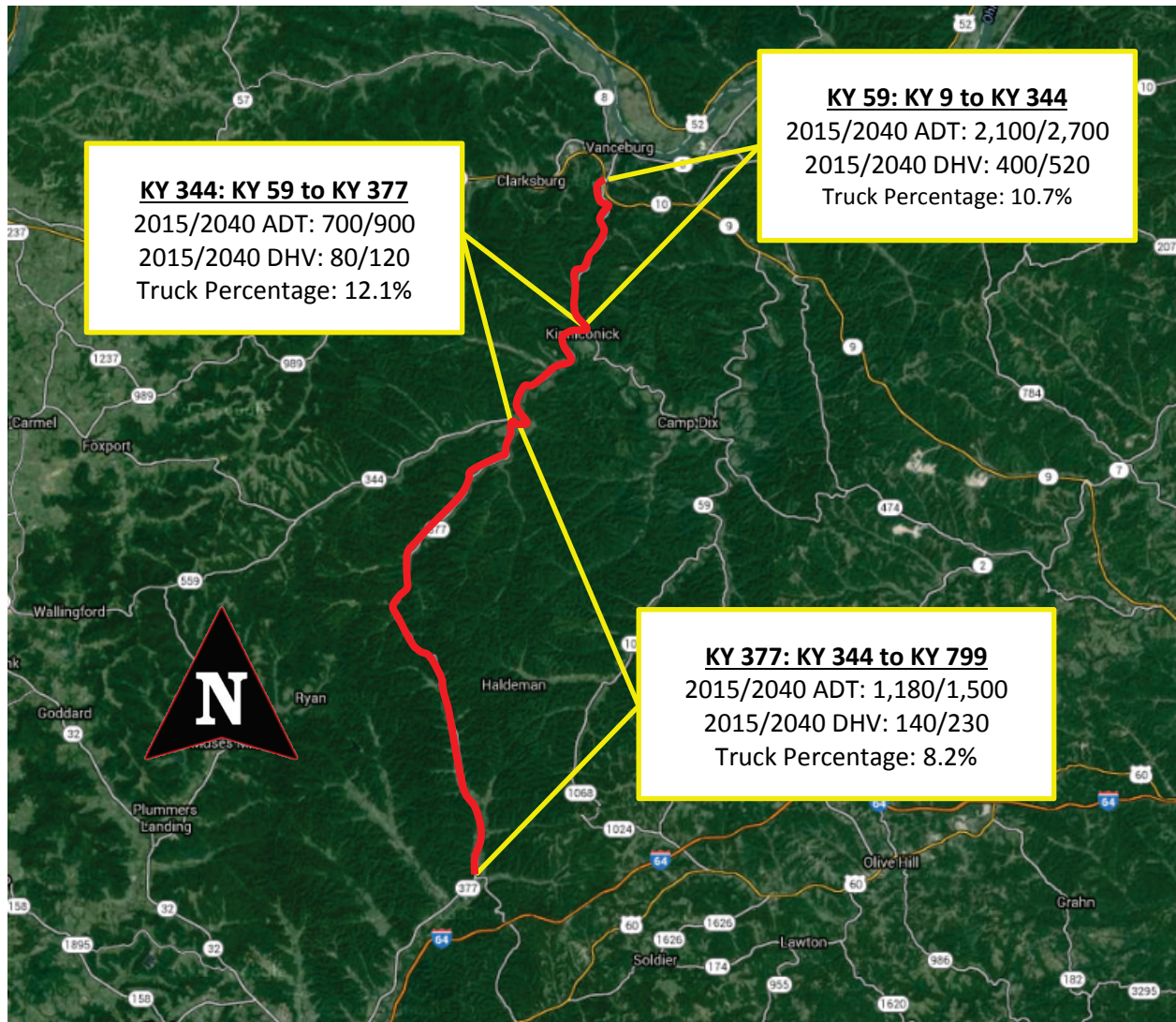

Existing Turning Movements

Lewis & Rowan Counties

KY 59 / KY 344 / KY 377 Forecast

NOTE: K-Factors, Directional Distributions, and Peak Hour Factors were determined from a 2008 Turning Movement Count. AM and PM DHVs represent 30th highest hour estimates for each turn maneuver.

PROJECT: KY 59 Lewis & Rowan
 ITEM NUMBER:
 MARS NUMBER:
 REQUEST DATE:
 ANALYST:
 SCENARIO: 2015 ADT and Design Hour Volumes
 INTERSECTION: T1: KY 9 & KY 59

****DHV TURN MOVEMENT FORECASTS SHOULD NOT BE USED FOR SIGNAL TIMING OR WARRANT ANALYSIS**

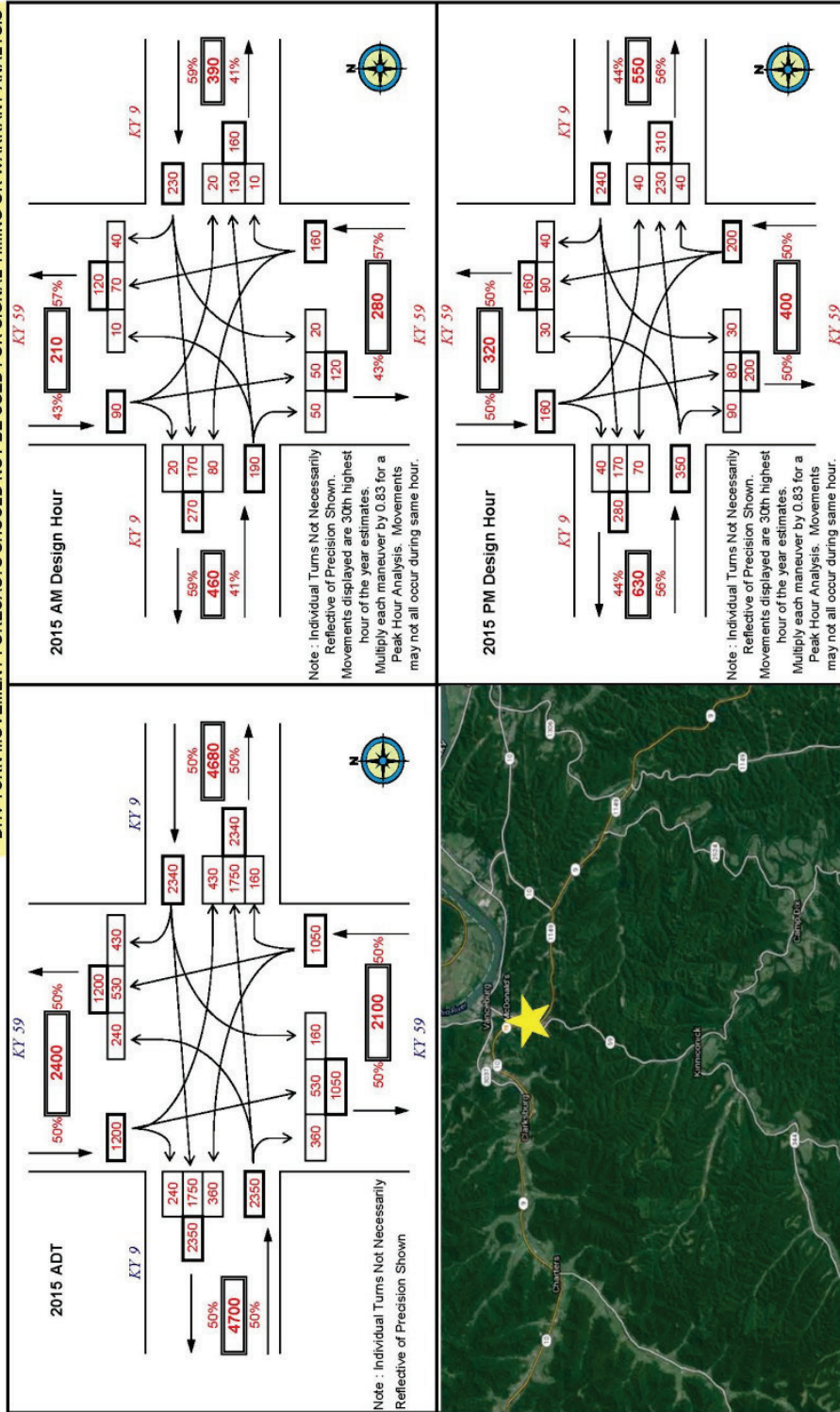

NOTE: K-Factors, Directional Distributions, and Peak Hour Factors were determined from a 2008 Turning Movement Count. AM and PM DHVs represent 30th highest hour estimates for each turn maneuver.

PROJECT: KY 59 Lewis & Rowan
 ITEM NUMBER: 0
 MARS NUMBER: 0
 REQUEST DATE: 1/0/1900
 ANALYST: 0
 SCENARIO: **2015 ADT and Design Hour Volumes**
 INTERSECTION: T2: KY 59 & KY 344

DHV TURN MOVEMENT FORECASTS SHOULD NOT BE USED FOR SIGNAL TIMING OR WARRANT ANALYSIS

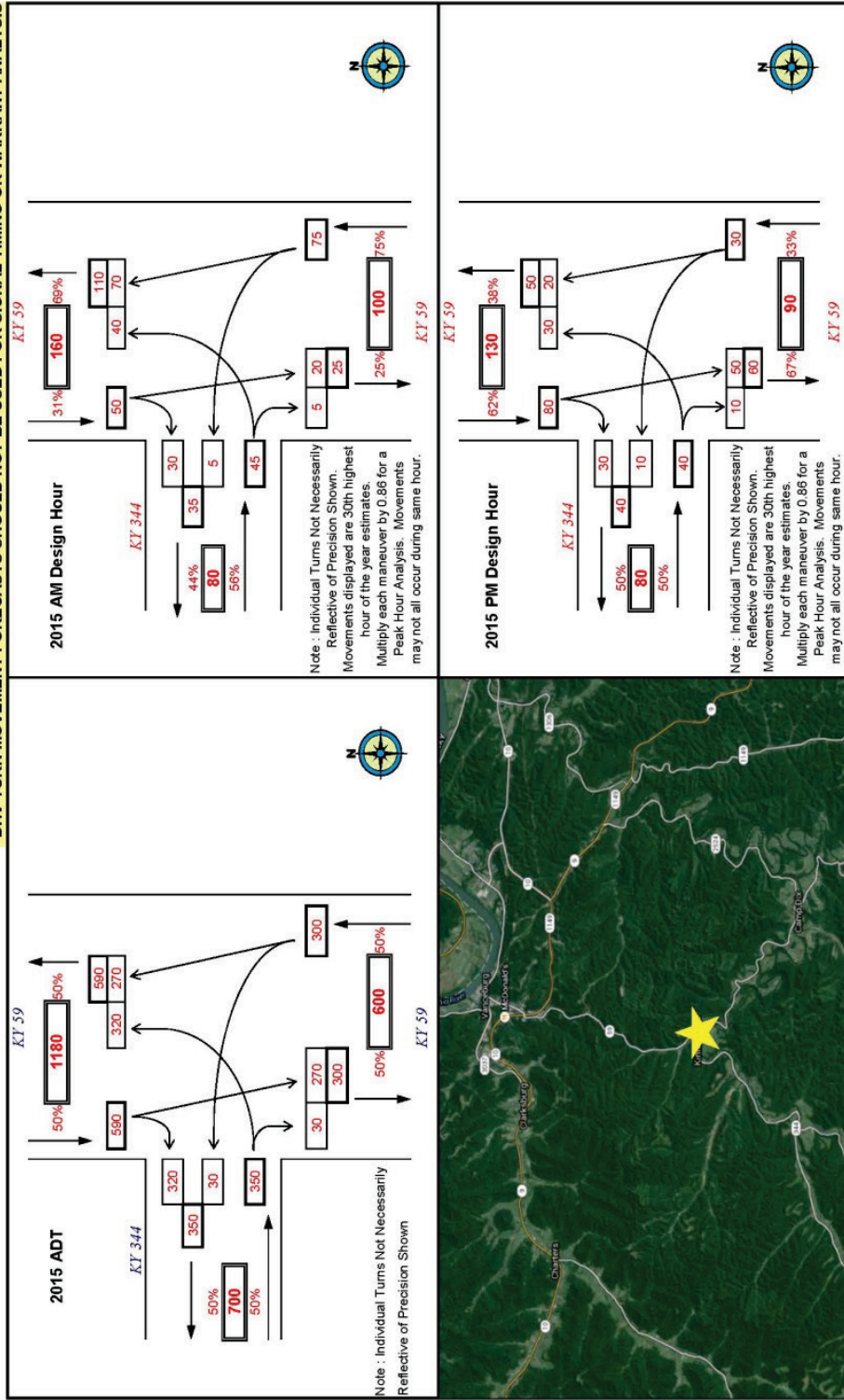

NOTE: K-Factors, Directional Distributions, and Peak Hour Factors were determined from a 2008 Turning Movement Count. AM and PM DHVs represent 30th highest hour estimates for each turn maneuver.

PROJECT: KY 59 Lewis & Rowan
 ITEM NUMBER:
 MARS NUMBER:
 REQUEST DATE:
 ANALYST:
 SCENARIO: 2015 ADT and Design Hour Volumes
 INTERSECTION: T3: KY 344 & KY 377

10th DHV TURN MOVEMENT FORECASTS SHOULD NOT BE USED FOR SIGNAL TIMING OR WARRANT ANALYSIS

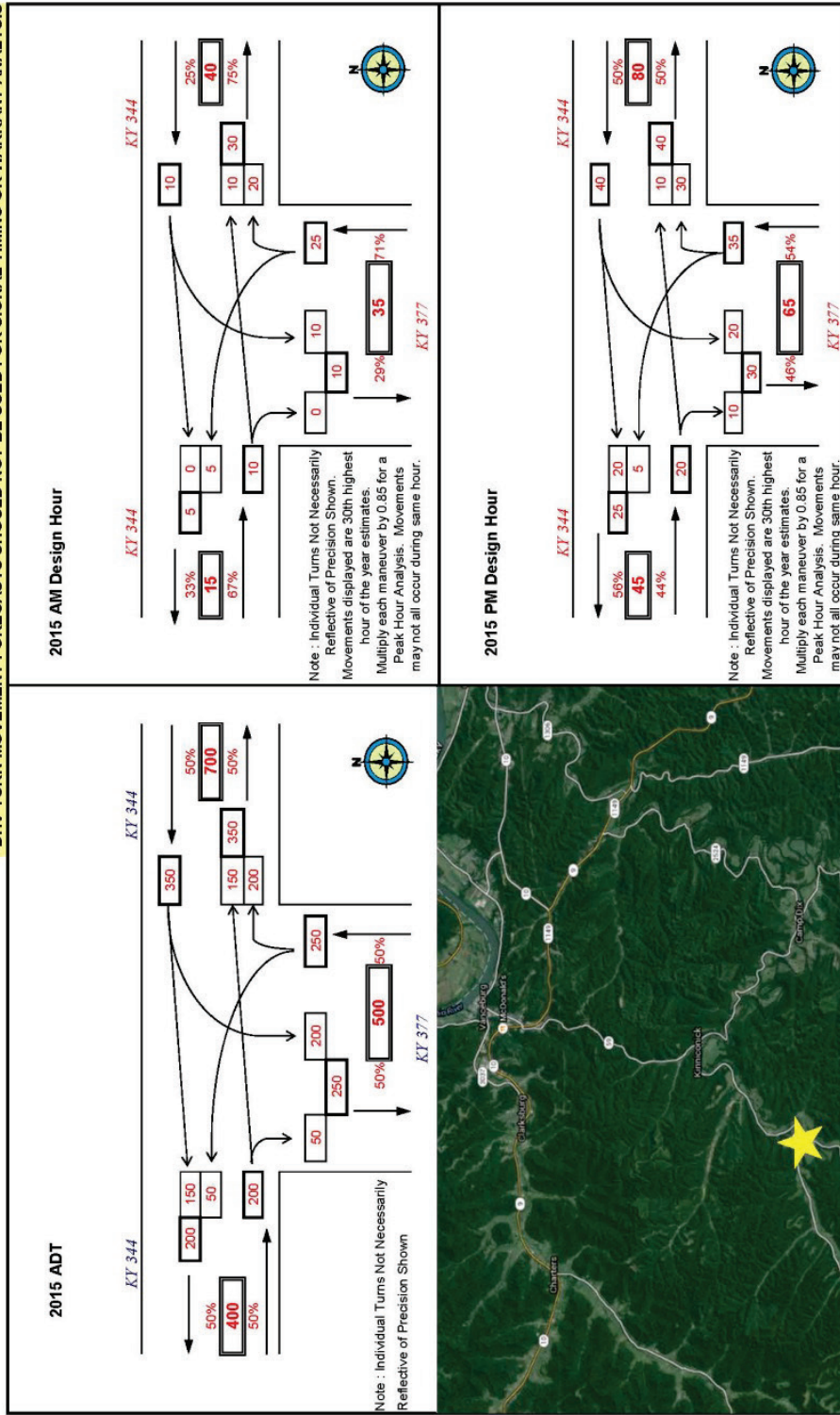

NOTE: K-Factors, Directional Distributions, and Peak Hour Factors were determined from a 2008 Turning Movement Count. AM and PM DHVs represent 30th highest hour estimates for each turn maneuver.

PROJECT: KY 59 Lewis & Rowan
 ITEM NUMBER:
 MARS NUMBER:
 REQUEST DATE:
 ANALYST:
 SCENARIO: 2014 ADT and Design Hour Volumes
 INTERSECTION: T4: KY 377 & KY 799

DHV TURN MOVEMENT FORECASTS SHOULD NOT BE USED FOR SIGNAL TIMING OR WARRANT ANALYSIS

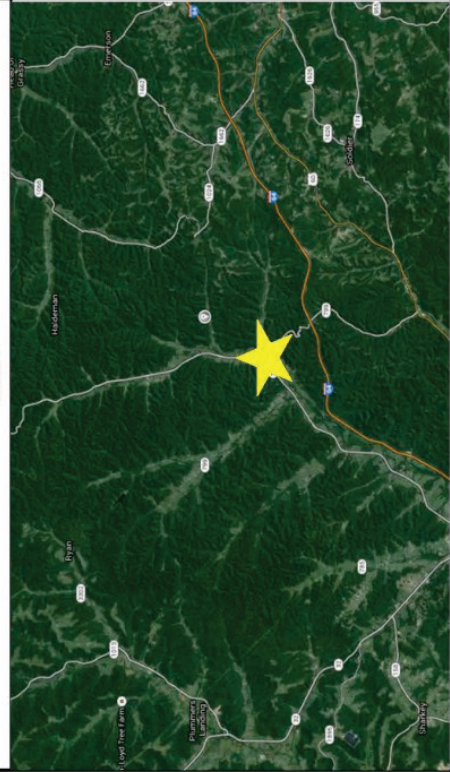
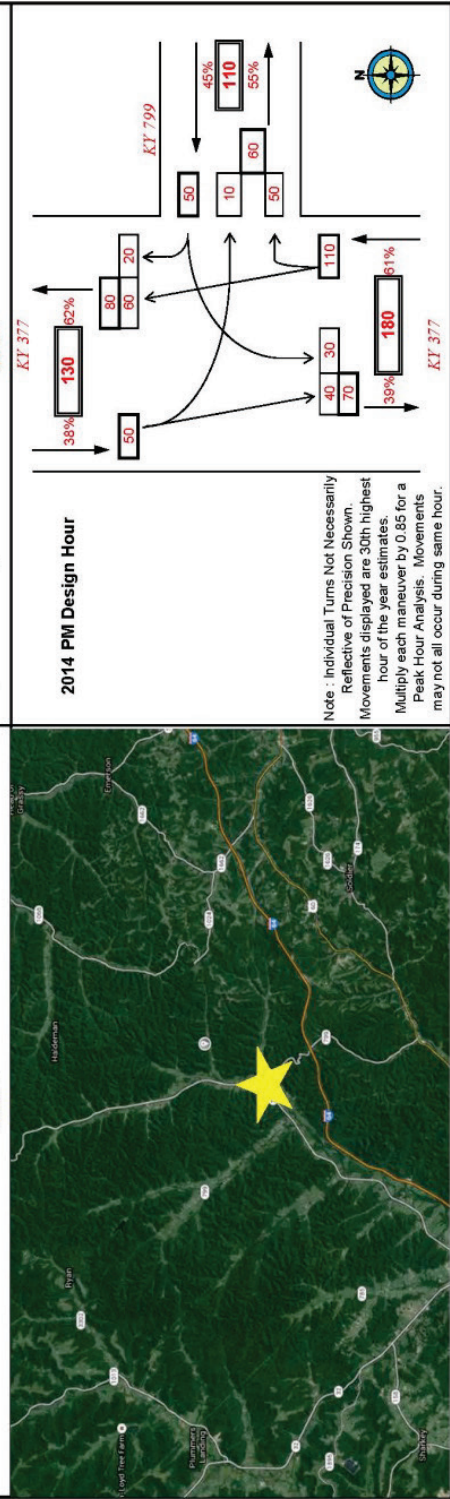
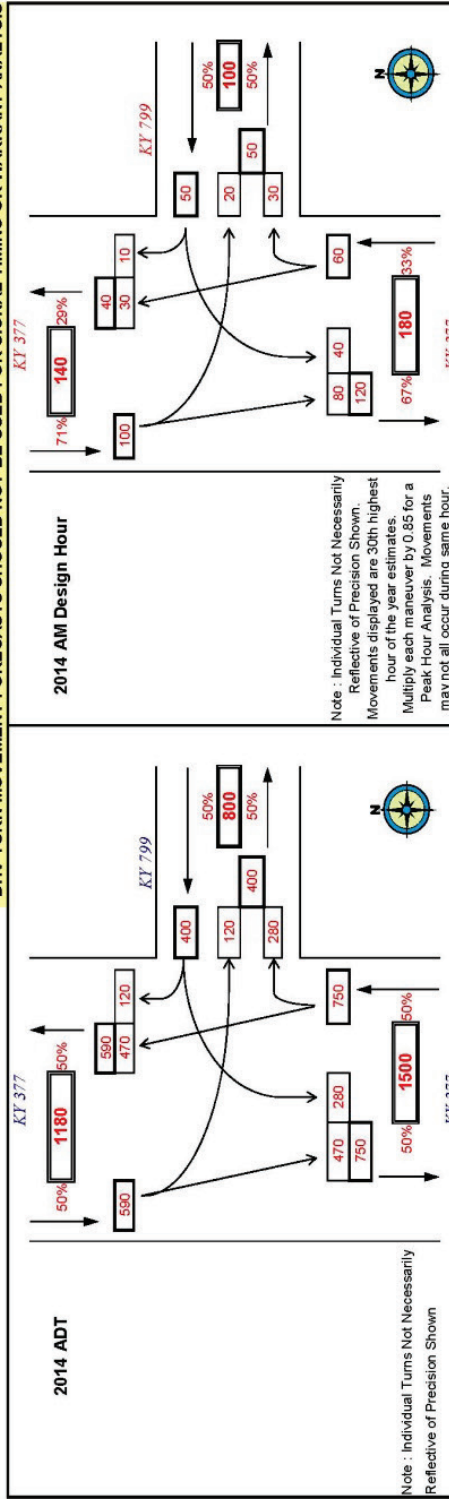

No Build / Build on Existing Alignment Turning Movements

Lewis & Rowan Counties

KY 59 / KY 344 / KY 377 Forecast

NOTE: K-Factors, Directional Distributions, and Peak Hour Factors were determined from a 2008 Turning Movement Count. AM and PM DHVs represent 30th highest hour estimates for each turn maneuver.

PROJECT: KY 59 Lewis & Rowan
 ITEM NUMBER: 0
 MARS NUMBER: 0
 REQUEST DATE: 1/01/2000
 ANALYST: 0
 SCENARIO: 2040 ADT and Design Hour Volumes
 INTERSECTION: T1: KY 9 & KY 59

***DHV TURN MOVEMENT FORECASTS SHOULD NOT BE USED FOR SIGNAL TIMING OR WARRANT ANALYSIS**

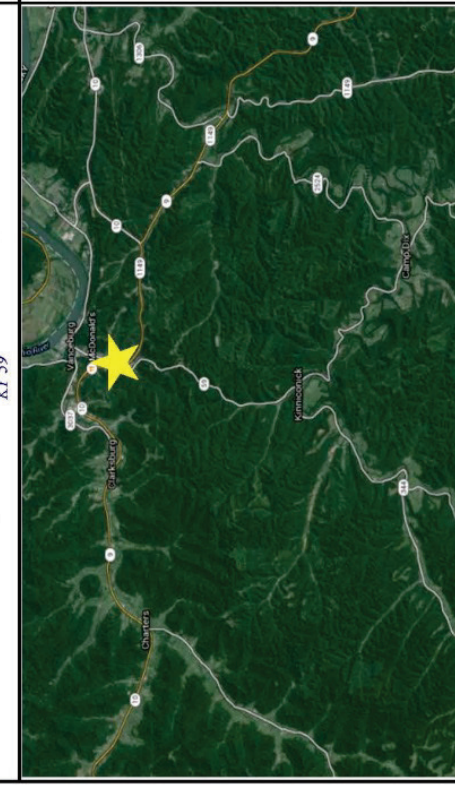
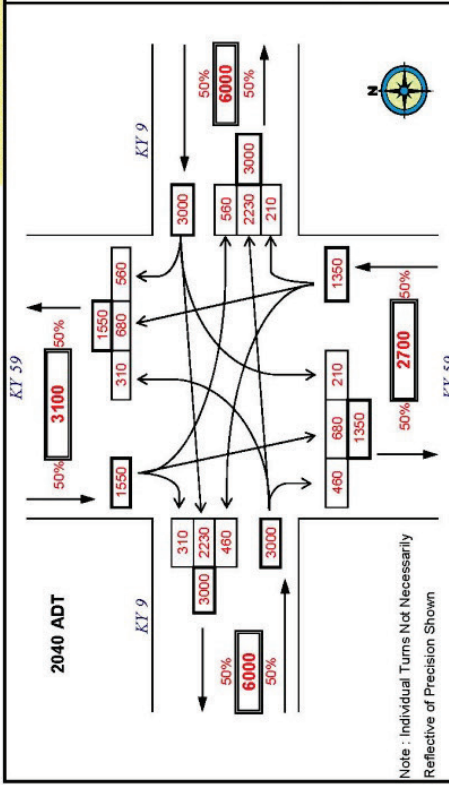
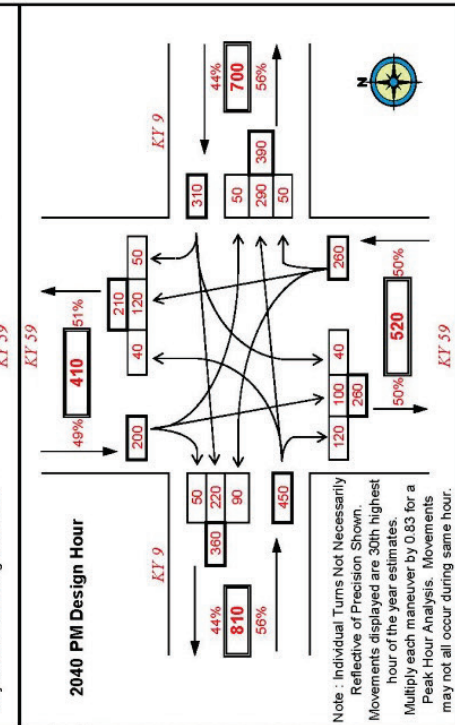
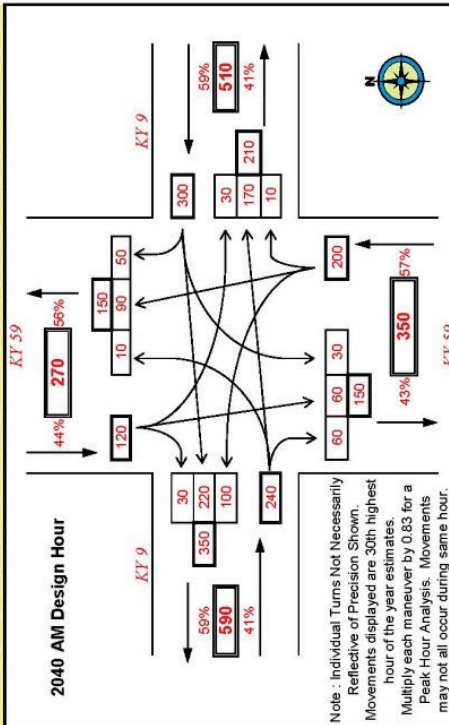

NOTE: K-Factors, Directional Distributions, and Peak Hour Factors were determined from a 2008 Turning Movement Count. AM and PM DHVs represent 30th highest hour estimates for each turn maneuver.

PROJECT: KY 59 Lewis & Rowan
 ITEM NUMBER: 0
 MARS NUMBER: 0
 REQUEST DATE: 1/0/1900
 ANALYST: 0
 SCENARIO: 2040 ADT and Design Hour Volumes
 INTERSECTION: T2: KY 59 & KY 344

"DHV TURN MOVEMENT FORECASTS SHOULD NOT BE USED FOR SIGNAL TIMING OR WARRANT ANALYSIS"

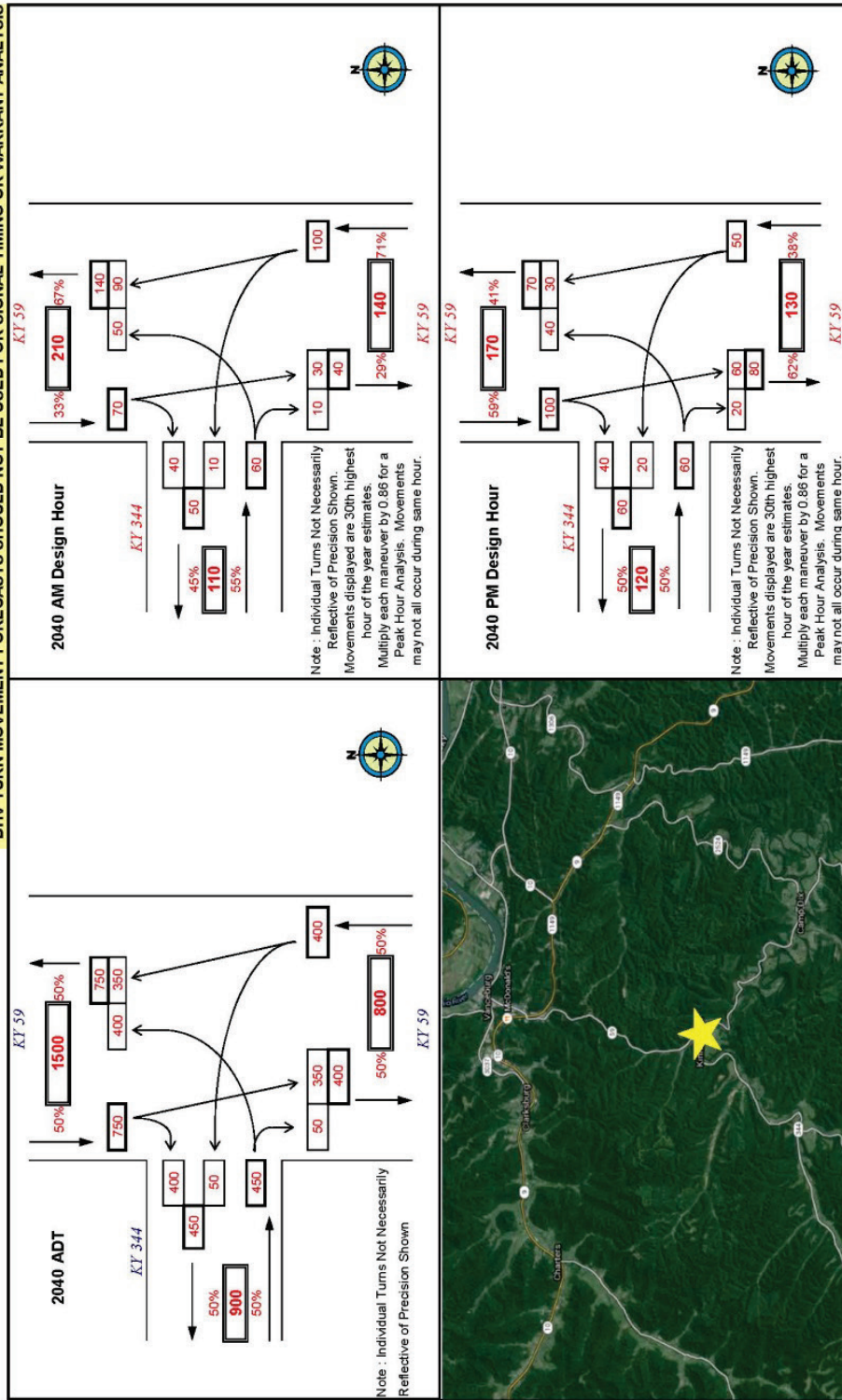

PROJECT: KY 59 Lewis & Rowan
ITEM NUMBER:
MARS NUMBER:
REQUEST DATE:
ANALYST:
SCENARIO: 2040 ADT and Design Hour Volumes
INTERSECTION: T3: KY 344 & KY 377

30th DHV TURN MOVEMENT FORECASTS SHOULD NOT BE USED FOR SIGNAL TIMING OR WARRANT ANALYSIS

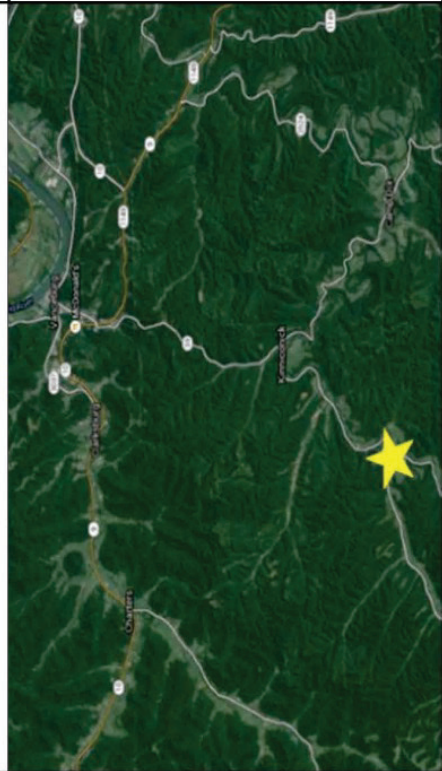
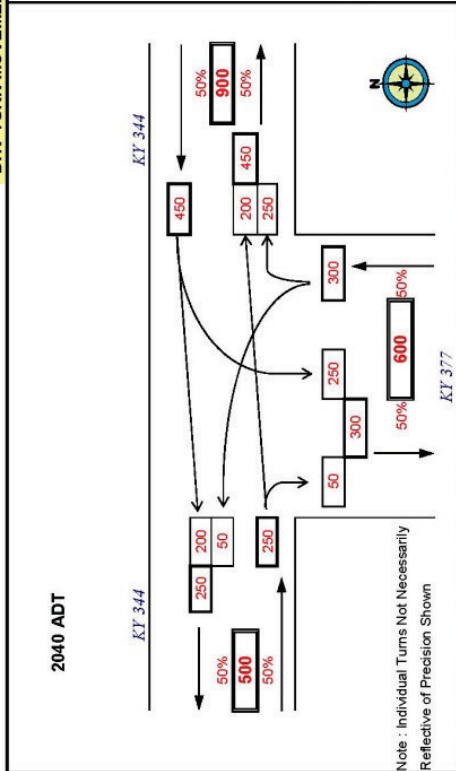
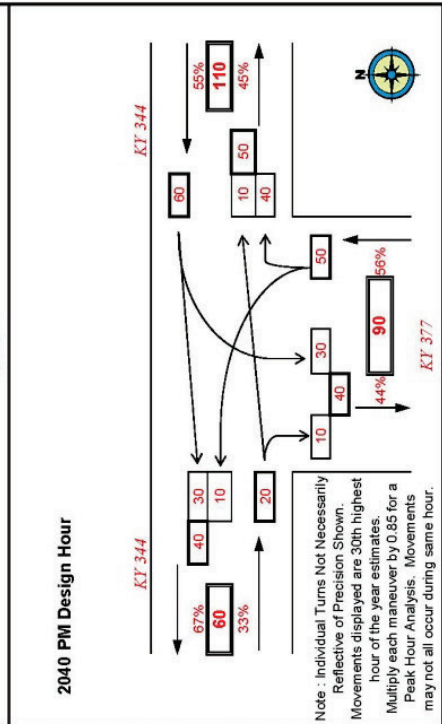
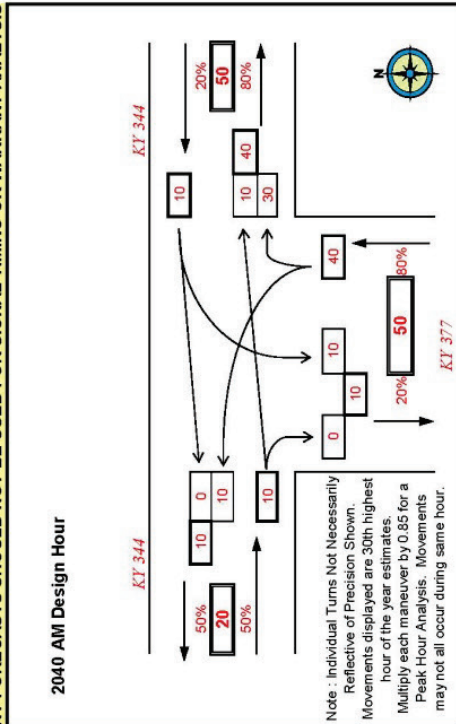

PROJECT: KY 59 Lewis & Rowan
 ITEM NUMBER:
 MARS NUMBER:
 REQUEST DATE:
 ANALYST:
 SCENARIO: 2040 ADT and Design Hour Volumes
 INTERSECTION: T4: KY 377 & KY 799

NOTE: K-Factors, Directional Distributions, and Peak Hour Factors were determined from a 2008 Turning Movement Count. AM and PM DHVs represent 30th highest hour estimates for each turn maneuver.

***DHV TURN MOVEMENT FORECASTS SHOULD NOT BE USED FOR SIGNAL TIMING OR WARRANT ANALYSIS**

